



JLS45BGS3-2

1-Line Bi-directional High Power TVS Diode

Jialan-Microelectronics

Description

The JLS45BGS3-2 is a bi-directional high power TVS diode, utilizing leading monolithic silicon technology to provide fast response time and low ESD clamping voltage, making this device an ideal solution for protecting voltage sensitive data and power line. The JLS45BGS3-2 complies with the IEC 61000-4-2 (ESD) standard with $\pm 30\text{kV}$ air and $\pm 30\text{kV}$ contact discharge. It is assembled into an ultra-small lead-free SOD-323 package. The small size and high ESD surge protection make JLS45BGS3-2 an ideal choice to protect cell phone, digital cameras, audio players and many other portable applications.

Circuit Diagram

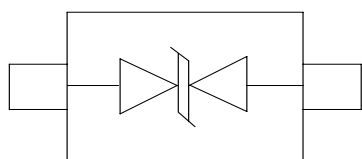

Circuit Diagram

Marking Diagram



Transparent top view

48D: Device Marking Code

Features

- * 2000W peak pulse power (8/20 μs)
- * Low leakage: nA level
- * Operating voltage: 4.5V
- * Ultra low clamping voltage
- * One power line protects
- * Complies with following standards:
 - IEC 61000-4-2 (ESD) immunity test
 - Air discharge: $\pm 30\text{kV}$
 - Contact discharge: $\pm 30\text{kV}$
 - IEC61000-4-5 (Lightning) 140A (8/20 μs)
- * RoHS Compliant
- * Package: SOD-323
- * Lead Finish: Sn

Applications

- * Mobile Phones and Accessories
- * Battery Protection
- * USB VBus
- * Power Line Protection
- * Hand Held Portable Applications

Ordering Information

Part Number	Packaging	Reel Size
JLS45BGS3-2	3000/Tape & Reel	7 inch



JLS45BGS3-2

Absolute Maximum Ratings ($T_A=25^\circ\text{C}$ unless otherwise specified)

Parameter	Symbol	Value	Unit
Peak Pulse Power (8/20 μs)	Ppk	2000	W
Peak Pulse Current (8/20 μs)	IPP	140	A
ESD per IEC 61000-4-2 (Air)	VESD	± 30	kV
ESD per IEC 61000-4-2 (Contact)		± 30	
Operating Temperature Range	TJ	-55 to +125	$^\circ\text{C}$
Storage Temperature Range	Tstg	-55 to +150	$^\circ\text{C}$

Electrical Characteristics ($T_A=25^\circ\text{C}$ unless otherwise specified)

Parameter	Symbol	Test Condition	Min	Typ	Max	Unit
Reverse Working Voltage	V_{RWM}				4.5	V
Breakdown Voltage	V_{BR}	$I_T = 1\text{mA}$	4.8			V
Reverse Leakage Current	I_R	$V_{RWM} = 4.5\text{V}$			1.0	μA
Clamping Voltage	V_C	$I_{PP} = 100\text{A}$ (8 x 20 μs pulse)		12.0		V
Clamping Voltage	V_C	$I_{PP} = 140\text{A}$ (8 x 20 μs pulse)			17.5	V
Junction Capacitance	C_J	$V_R = 0\text{V}$, $f = 1\text{MHz}$		300	400	pF

Portion Electronics Parameter

Symbol	Parameter
I_T	Test Current
I_{PP}	Maximum Reverse Peak Pulse Current
V_C	Clamping Voltage @ I_C

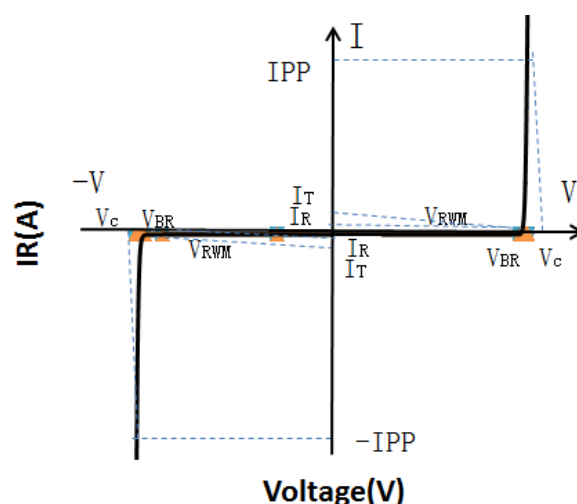



JLS45BGS3-2

Typical Performance Characteristics ($T_A=25^\circ\text{C}$ unless otherwise Specified)

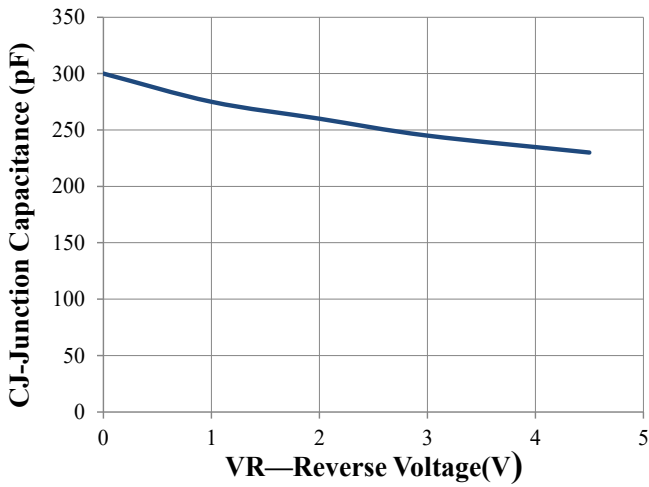

Junction Capacitance vs. Reverse Voltage

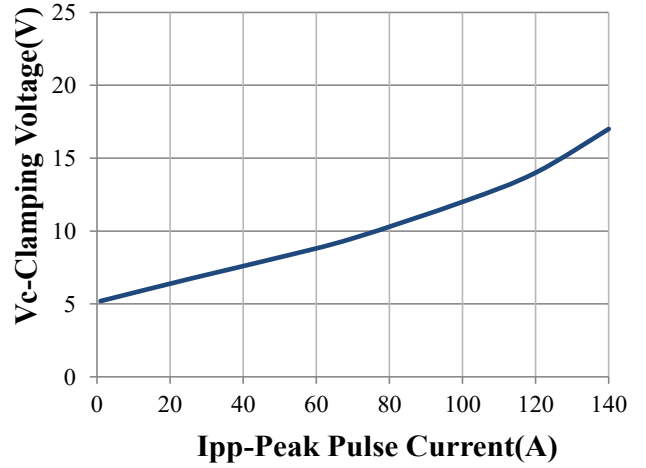

Clamping Voltage vs. Peak Pulse Current

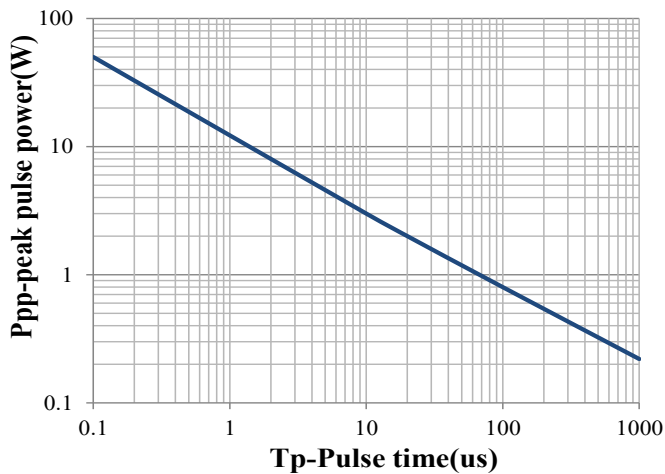

Peak Pulse Power vs. Pulse Time

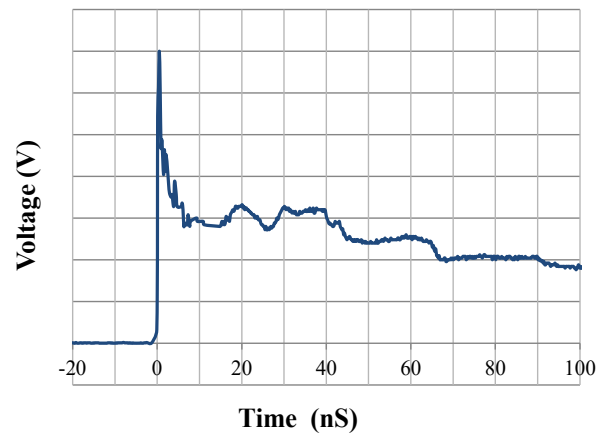

IEC61000-4-2 Pulse Waveform

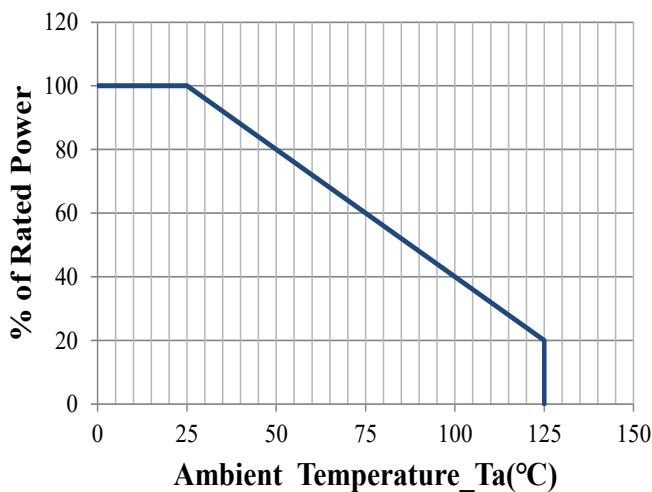

Power Derating Curve

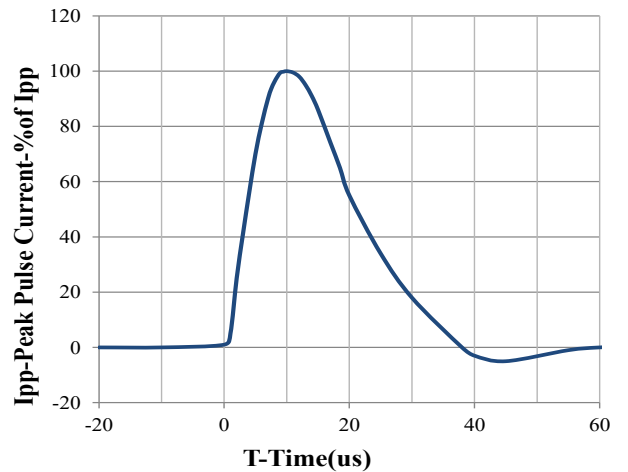

8 X 20us Pulse Waveform



JLS45BGS3-2

SOD-323 Package Outline Drawing

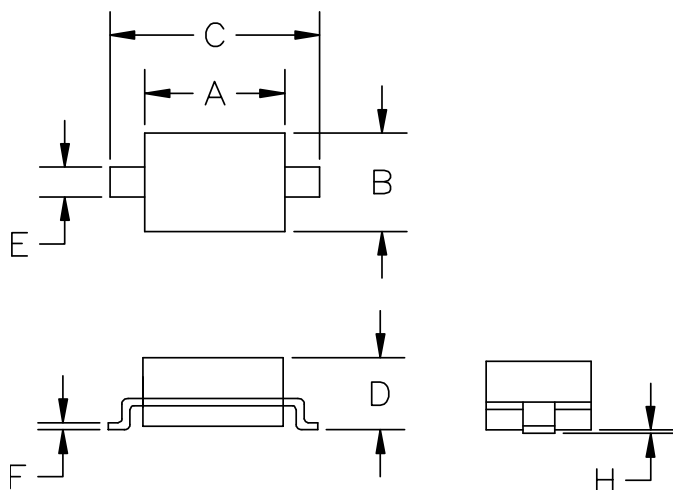

SYM	DIMENSIONS			
	MILLIMETERS		INCHES	
	MIN	MAX	MIN	MAX
A	1.50	1.80	0.060	0.071
B	1.20	1.40	0.045	0.054
C	2.30	2.70	0.090	0.107
D	-	1.10	-	0.043
E	0.30	0.40	0.012	0.016
F	0.10	0.25	0.004	0.010
H	-	0.10	-	0.004

Suggested Land Pattern

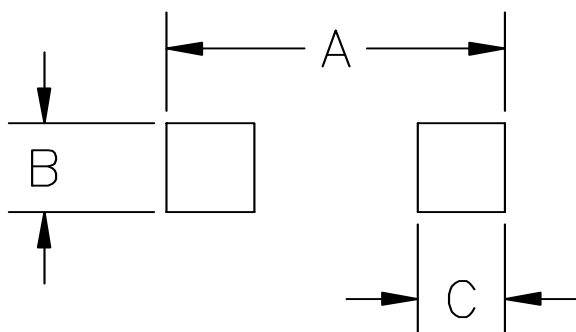

SYM	DIMENSIONS	
	MILLIMETERS	INCHES
A	3.15	0.120
B	0.80	0.031
C	0.80	0.031

NOTICE

Jelan-Link reserves the right to make changes without further notice to any products here in.

Only obligations are those in the Jelan-Link Standard Terms and Conditions of Sale and in no case will Jelan-Link be liable for any incidental, indirect, or consequential damages arising from the sale, resale, use, or misuse of its products.